

Schaltbild Vorverstärker

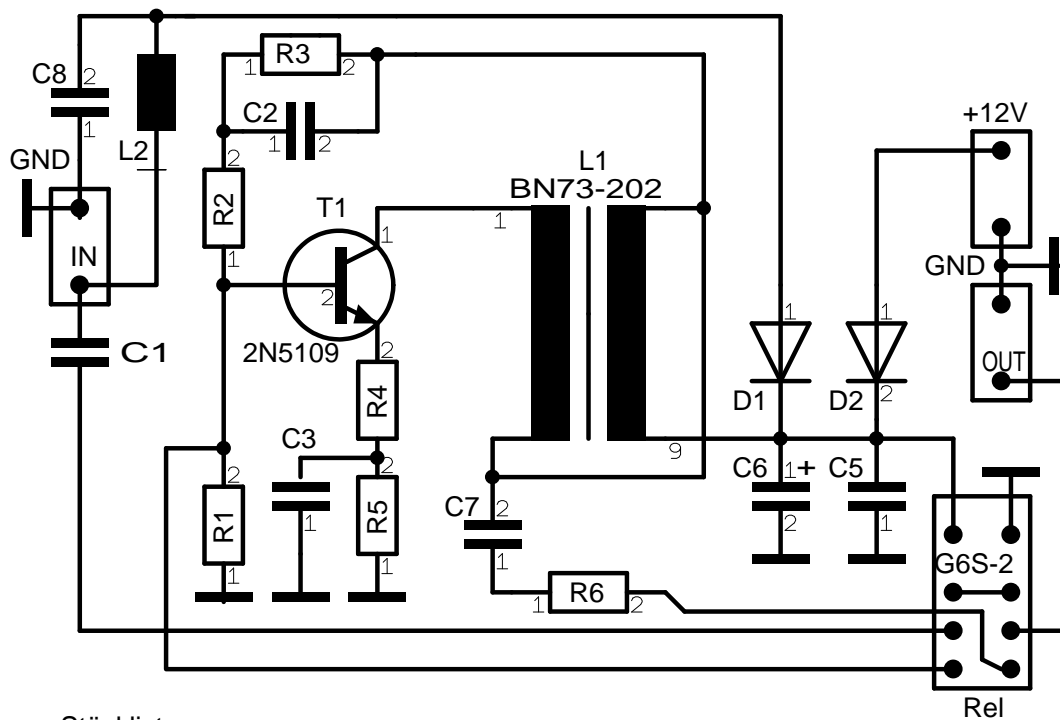

Stückliste

- R1 1K 1% 0,25W
- R2 680 1% 0,25W
- R3 3,3K 1% 0,25W
- R4 6,8 1% 0,25W
- R5 12 1% 0,25W
- R6 3,0 5% 0,25W
- T1 2N5109
- L1 BN73-202 3/12 Windungen
- L2 Spule SMCC 220 μ H
- C1,C2,C3,C4,C5,C7,C8 100n keram.
- C6 Elko 22 μ F 63V
- D1 , D2 1N4007
- Relais Omron G6S-2